

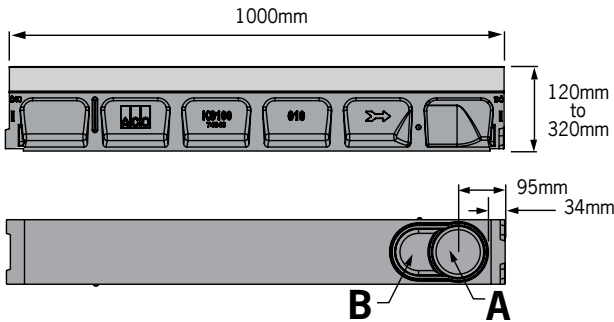

One metre channel

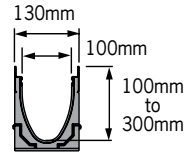

Knock-outs included on every 5th channel



Half metre channel

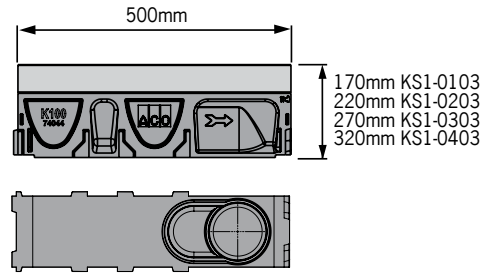

KS1-901S In-line pit

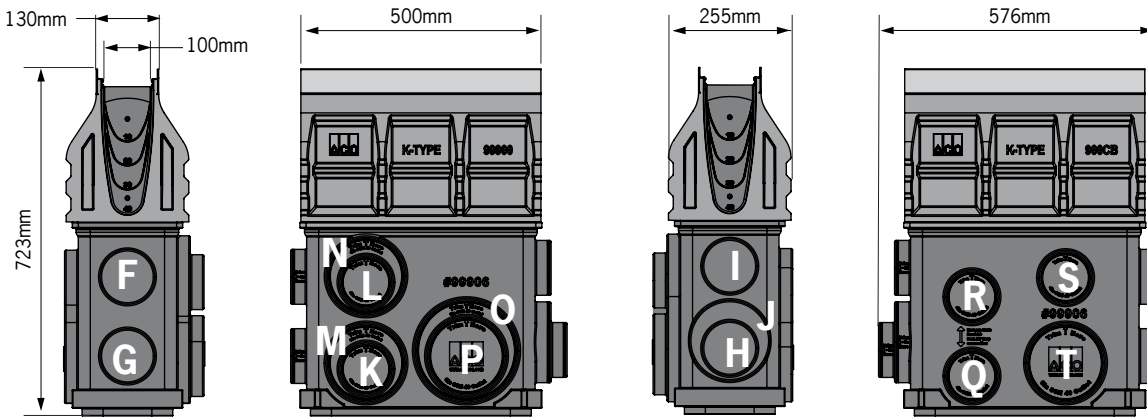

Total capacity = 40 litres

Outlet flow rates

Outlet	Product	Outlet size	Invert Depth (mm)	L/s
A	Bottom outlet - KS1-00	100mm round	100	7.2
A	Bottom outlet - KS1-040	100mm round	300	12.4
B	Bottom outlet - KS1-00	150mm oval	100	11.7
B	Bottom outlet - KS1-040	150mm oval	300	20.3
C	End outlet - KS1-020	100mm round	200	7.2
C	End outlet - KS1-040	100mm round	300	10.1
F	KS1-901S	100mm round	490	14.1
G	KS1-901S	100mm round	652	16.8
H	KS1-901S	100mm round	643	16.7
I	KS1-901S	100mm round	471	13.8
J	KS1-901S	150mm round	657	36.2
K	KS1-901S	100mm round	671	17.1
L	KS1-901S	100mm round	492	14.2
M	KS1-901S	150mm round	693	37.5
N	KS1-901S	150mm round	508	30.4
O	KS1-901S	200mm round	693	63.5
P	KS1-901S	150mm round	671	36.7
Q	KS1-901S	100mm round	690	17.4
R	KS1-901S	100mm round	525	14.7
S	KS1-901S	100mm round	482	14.0
T	KS1-901S	150mm round	690	37.4

Note: These are the pipe flow rates at the specified outlet, NOT channel flow rates.  
In-line pit flow rates are without rubbish basket – using rubbish basket reduces flow.

End Cap

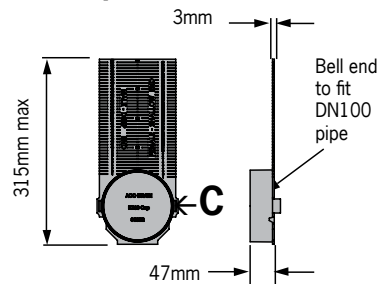



Description	Part No.	Invert <sup>2</sup> (mm)	Weight (kg)
<b>KS1-00 Neutral channel - (1m)<sup>1</sup></b>	<b>144441</b>	<b>100</b>	<b>12.7</b>
KS1-1 Sloped channel - (1m)	144401	105	12.7
KS1-2 Sloped channel - (1m)	144402	110	13.1
KS1-3 Sloped channel - (1m)	144403	115	13.5
KS1-4 Sloped channel - (1m)	144404	120	13.8
KS1-5 Sloped channel - (1m) <sup>1</sup>	144405	125	14.2
KS1-6 Sloped channel - (1m)	144406	130	14.6
KS1-7 Sloped channel - (1m)	144407	135	14.9
KS1-8 Sloped channel - (1m)	144408	140	15.3
KS1-9 Sloped channel - (1m)	144409	145	15.6
KS1-10 Sloped channel - (1m) <sup>1</sup>	144410	150	16.0
<b>KS1-010 Neutral channel - (1m)<sup>1</sup></b>	<b>144443</b>	<b>150</b>	<b>16.0</b>
<b>KS1-0103 Neutral channel - (0.5m)<sup>1</sup></b>	<b>144444</b>	<b>150</b>	<b>7.7</b>
KS1-11 Sloped channel - (1m)	144411	155	16.4
KS1-12 Sloped channel - (1m)	144412	160	16.7
KS1-13 Sloped channel - (1m)	144413	165	17.1
KS1-14 Sloped channel - (1m)	144414	170	17.5
KS1-15 Sloped channel - (1m) <sup>1</sup>	144415	175	17.8
KS1-16 Sloped channel - (1m)	144416	180	18.2
KS1-17 Sloped channel - (1m)	144417	185	18.6
KS1-18 Sloped channel - (1m)	144418	190	18.9
KS1-19 Sloped channel - (1m)	144419	195	19.3
KS1-20 Sloped channel - (1m) <sup>1</sup>	144420	200	19.7
<b>KS1-020 Neutral channel - (1m)<sup>1</sup></b>	<b>144445</b>	<b>200</b>	<b>19.7</b>
<b>KS1-0203 Neutral channel - (0.5m)<sup>1</sup></b>	<b>144446</b>	<b>200</b>	<b>9.3</b>
KS1-21 Sloped channel - (1m)	144421	205	20.0
KS1-22 Sloped channel - (1m)	144422	210	20.4
KS1-23 Sloped channel - (1m)	144423	215	20.8
KS1-24 Sloped channel - (1m)	144424	220	21.1
KS1-25 Sloped channel - (1m) <sup>1</sup>	144425	225	21.5
KS1-26 Sloped channel - (1m)	144426	230	21.9
KS1-27 Sloped channel - (1m)	144427	235	22.2

Description	Part No.	Invert <sup>2</sup> (mm)	Weight (kg)
KS1-28 Sloped channel - (1m)	144428	240	22.6
KS1-29 Sloped channel - (1m)	144429	245	23.0
KS1-30 Sloped channel - (1m) <sup>1</sup>	144430	250	23.3
<b>KS1-030 Neutral channel - (1m)<sup>1</sup></b>	<b>144447</b>	<b>250</b>	<b>23.3</b>
<b>KS1-0303 Neutral channel - (0.5m)<sup>1</sup></b>	<b>144448</b>	<b>250</b>	<b>10.9</b>
KS1-31 Sloped channel - (1m)	144431	255	23.7
KS1-32 Sloped channel - (1m)	144432	260	24.0
KS1-33 Sloped channel - (1m)	144433	265	24.4
KS1-34 Sloped channel - (1m)	144434	270	24.8
KS1-35 Sloped channel - (1m) <sup>1</sup>	144435	275	25.1
KS1-36 Sloped channel - (1m)	144436	280	25.5
KS1-37 Sloped channel - (1m)	144437	285	25.9
KS1-38 Sloped channel - (1m)	144438	290	26.3
KS1-39 Sloped channel - (1m)	144439	295	26.6
KS1-40 Sloped channel - (1m) <sup>1</sup>	144440	300	27.0
<b>KS1-040 Neutral channel - (1m)<sup>1</sup></b>	<b>144449</b>	<b>300</b>	<b>27.0</b>
<b>KS1-0403 Neutral channel - (0.5m)<sup>1</sup></b>	<b>144450</b>	<b>300</b>	<b>12.5</b>
KS1-901S In-line pit (0.5m) <sup>3</sup>	141818	723 <sup>4</sup>	23.9
Type 900 In-line plastic rubbish basket	01498	-	0.5
Universal end cap	96822	315 <sup>4</sup>	0.2
Debris strainer for 100mm knockout	93488	-	0.1
Installation device	97477	-	1.3
Grate removal tool	01318	-	0.1
QuickLok bar	02899	-	0.1

**Notes:**

1. This channel offers bottom knockout feature; 100mm round & 150mm oval.
2. Inverts shown are male end, for female invert depths - subtract 5mm from male invert (except neutral channels where it will be the same as the male invert). To calculate overall channel depth add 20mm to invert depth.
3. In-line pit assembly (polymer concrete top with stainless steel edge rail, plastic base & removable QuickLok Bar). Select appropriate grate to suit.
4. Overall depth of in-line pit and end caps.

**Specifications**

The surface drainage system shall be ACO's KlassikDrain KS100 polymer concrete V-profile channel system with stainless steel edge rails as manufactured by ACO.

**Channels**

KS100 channel shall be 100mm nominal internal width with an overall width of 130mm. Channel invert shall have a V-profile to allow efficient drainage. KS100 sloped channels shall have a built-in slope of 0.5%. All channels shall be interlocking with a male/female joint

**Grates**

Insert specification for the selected grate. Refer to the relevant ACO Specification Information sheet, click: <http://www.acodrain.com.au/resources>

**Installation**

The complete drainage system shall be by ACO and to be installed for its intended purpose. Any deviation or partial use of the specified system and/or improper installation will void all warranties provided by ACO.

**Materials**

KS100 channels shall be manufactured from polyester resin polymer concrete with integrally cast-in stainless steel edge rails.

Properties of polymer concrete will be as follows with supporting documentation:

Compressive Strength:	98 MPa
Flexural Strength:	26 MPa
Tensile Strength:	14 MPa
Water Absorption:	0.07%
Frost Proof:	YES
Coefficient of Expansion and Contraction:	2.02x10 <sup>-5</sup> /°C
Water Vapour Transmission:	0.0364g/m2
Non Flammable:	YES
Roughness (Mannings):	n=0.011
Resistant to Weathering:	YES
Dilute Acid and Alkali Resistant:	YES
SF Sealant Groove:	YES

**ACO Polycrete Pty Ltd  
Australia**

Ph: 1300 765 226  
www.acodrain.com.au  
sales@acoaus.com.au

**ACO Limited  
New Zealand**

Ph: 0800 448 080  
www.acodrain.co.nz  
sales@aconz.co.nz

