

**Type 33 Polycrete® Pit – polymer concrete pit and grate**

**Stainless 5 Star grate**

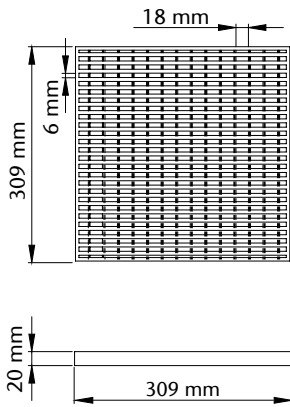

**Galvanised Heelguard grate**

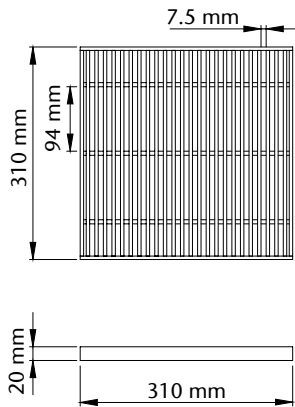

**Galvanised Transverse grate**

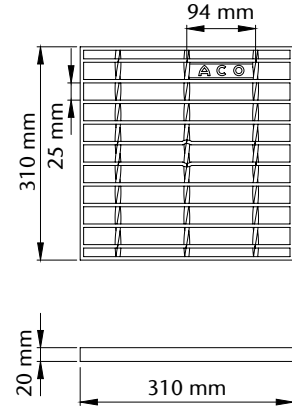

**Drainage pit**

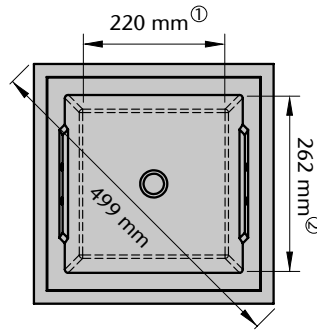

**Key**

- ① Clear working dimension at pit base.
- ② Clear working dimension at pit opening.
- ③ Pit invert depth.

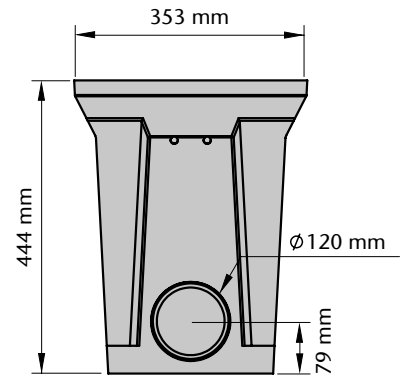
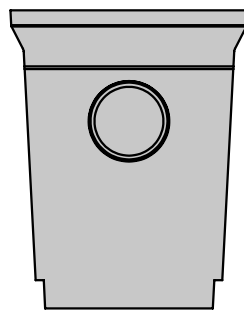
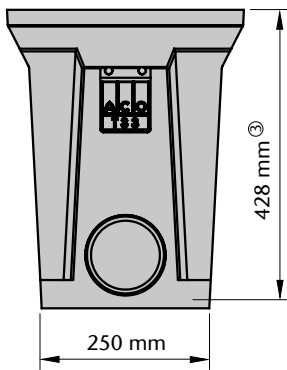

**Optional riser**

- each riser adds up to 300mm height

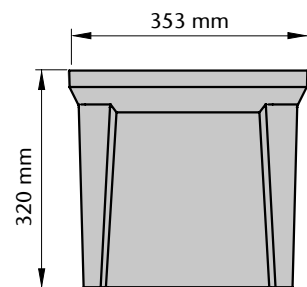
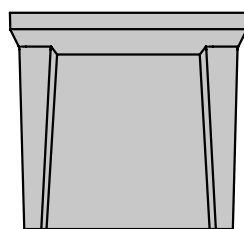
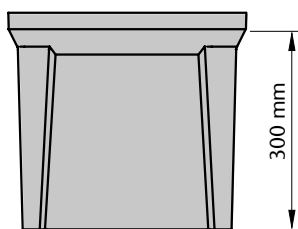
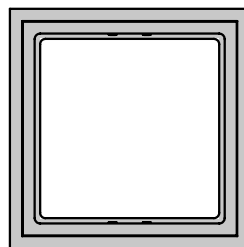

ACO Specification Information

## ACO DRAIN®

### Type 33 Polycrete® Pit – polymer concrete pit and grate

Pit/riser and grates				
Descriptions	Part No.	Slot Size (mm)	Intake Area (mm <sup>2</sup> )	Weight (kg)
Type 33 Polymer concrete pit	77003	-	-	19
Type 33 Polymer concrete riser	77031	-	-	15
Type 33 Stainless 5 Star <b>Heelsafe</b> ® <i>Anti-Slip</i> grate (330kg nominal wheel load)	141808	18 x 6	42,540	3.1
Type 33 Stainless 5 Star <b>Heelsafe</b> ® <i>Anti-Slip</i> grate - locking (330kg nominal. wheel load)	142073	18 x 6	42,540	3.1
Type 33 Galvanised Heelguard grate (2,670kg nominal wheel load)	90038	94 x 7.5	50,760	5.9
Type 33 Galvanised Heelguard grate - locking (2,670kg nominal wheel load)	78678	94 x 7.5	50,760	5.9
Type 33 Galvanised Transverse grate (2,670kg nominal wheel load)	78665	94 x 25	70,500	3.4
Type 33 Galvanised Transverse grate - locking (2,670kg nominal wheel load)	78677	94 x 25	70,500	3.4

#### Notes:

1. Locking grate includes bar and brackets.
2. Stainless steel grade 304.

#### Specifications

The grated pit shall be ACO Drain® - Type 33 Polycrete® Pit – polymer concrete pit and grate as manufactured by ACO.

Type 33 pit and risers\* shall be manufactured from polyester resin polymer concrete and installed in accordance with the manufacturer's installation instructions.

Type 33 pits have a clear opening of 262mm x 262mm with an invert depth of 428mm. The overall dimensions of the Type 33 pit is 353mm x 353mm x 444mm deep. Type 33 risers add 300mm to the overall depth of the pit.\*

Grate for the Type 33 pit shall be standard non-locking / locking\* and grate type,

- Stainless 5 Star **Heelsafe**® *Anti-Slip* grate (330kg nominal wheel load).\*
- Galvanised Heelguard grate (2,670kg nominal wheel load).\*
- Galvanised Transverse grate (2,670kg nominal wheel load).\*

\* delete as applicable

#### ACO Pty Ltd

Australia

Ph: 1300 765 226

[www.acoaus.com.au](http://www.acoaus.com.au)

[sales@acoaus.com.au](mailto:sales@acoaus.com.au)

©2019 ACO Pty Ltd. All reasonable care has been taken in compiling the information in this document. All recommendations and suggestions on the use of ACO products are made without guarantee since the conditions of use are beyond the control of the company. It is the customer's responsibility to ensure that each product is fit for its intended purpose and that the actual conditions are suitable. ACO Pty Ltd. pursues a policy of continuous product development and reserves the right to amend specifications without notice.

