

Type 95 Polycrete® Pit – polymer concrete pit and grate

Stainless 5 Star grate

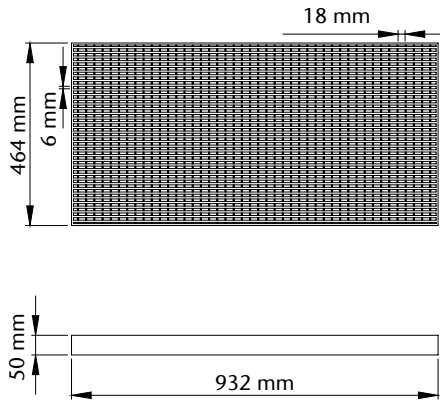

Galvanised Heelguard grate

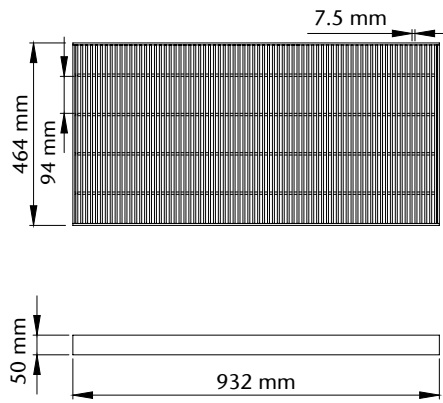

Galvanised Transverse grate

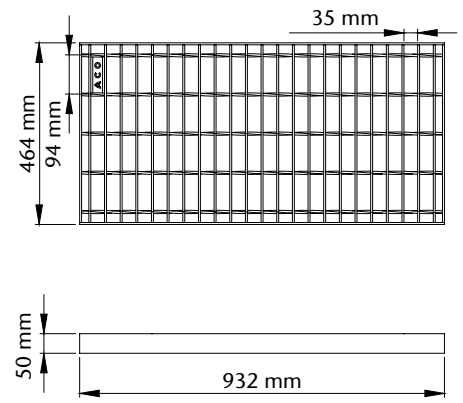

Drainage pit

Key

- ① Clear working dimension at pit base.
- ② Clear working dimension at pit opening.
- ③ Pit invert depth.

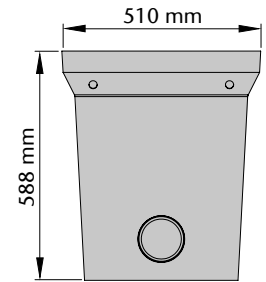
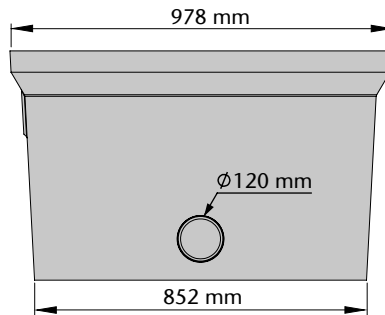
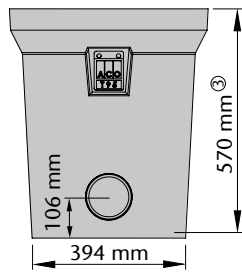
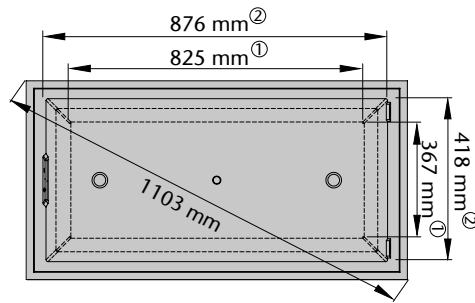

Optional riser

- each riser adds up to 300mm height

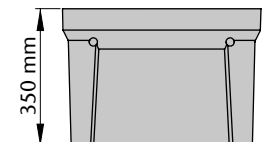
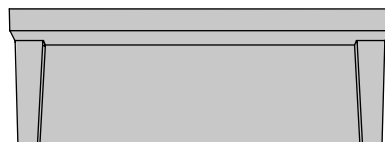
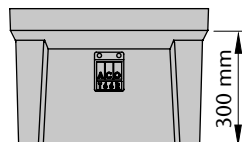
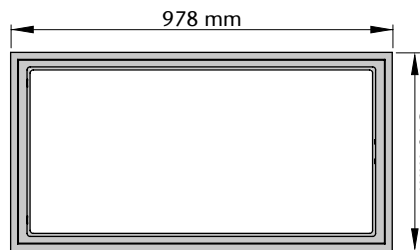

ACO Specification Information

ACO DRAIN®

Type 95 Polycrete® Pit – polymer concrete pit and grate

Pit/riser and grates				
Descriptions	Part No.	Slot Size (mm)	Intake Area (mm ²)	Weight (kg)
Type 95 Polymer concrete pit	77055	-	-	84
Type 95 Polymer concrete riser	77093	-	-	45
Type 95 Stainless 5 Star Heelsafe ® Anti-Slip grate (330kg nominal wheel load)	141811	18 x 6	198,000	15.6
Type 95 Stainless 5 Star Heelsafe ® Anti-Slip grate - locking (330kg nominal wheel load)	142076	18 x 6	198,000	15.6
Type 95 Galvanised Heelguard grate (2,670kg nominal wheel load)	90067	94 x 7.5	233,750	56.0
Type 95 Galvanised Heelguard grate - locking (2,670kg nominal wheel load)	78681	94 x 7.5	233,750	56.0
Type 95 Galvanised Transverse grate (2,670kg nominal wheel load)	78731	94 x 35	342,125	18.5
Type 95 Galvanised Transverse grate - locking (2,670kg nominal wheel load)	78725	94 x 35	342,125	18.5
Type 95 Galvanised Transverse grate (5,000kg nominal wheel load)	77662	94 x 35	342,125	27.9
Type 95 Galvanised Transverse grate - locking (5,000kg nominal wheel load)	77658	94 x 35	342,125	27.9

Notes:

1. Locking grate includes bar and brackets.
2. Stainless steel grade 304.

Specifications

The grated pit shall be ACO Drain® - Type 95 Polycrete® Pit – polymer concrete pit and grate as manufactured by ACO.

Type 95 pit and risers* shall be manufactured from polyester resin polymer concrete and installed in accordance with the manufacturer's installation instructions.

Type 95 pits have a clear opening of 876mm x 418mm with an invert depth of 570mm. The overall dimensions of the Type 95 pit is 978mm x 510mm x 588mm deep. Type 95 risers add 300mm to the overall depth of the pit.*

Grate for the Type 95 pit shall be standard non-locking / locking* and grate type:

- Stainless 5 Star **Heelsafe**® Anti-Slip grate (330kg nominal wheel load).*
- Galvanised Heelguard grate (2,670kg nominal wheel load).*
- Galvanised Transverse grate (2,670kg nominal wheel load).*
- Galvanised Transverse grate (5,000kg nominal wheel load).*

* delete as applicable

ACO Pty Ltd

Australia

Ph: 1300 765 226

www.acoaus.com.au

sales@acoaus.com.au

©2019 ACO Pty Ltd. All reasonable care has been taken in compiling the information in this document. All recommendations and suggestions on the use of ACO products are made without guarantee since the conditions of use are beyond the control of the company. It is the customer's responsibility to ensure that each product is fit for its intended purpose and that the actual conditions are suitable. ACO Pty Ltd. pursues a policy of continuous product development and reserves the right to amend specifications without notice.

