

Type 99 Polycrete® Pit – polymer concrete pit and grate

Stainless 5 Star grate

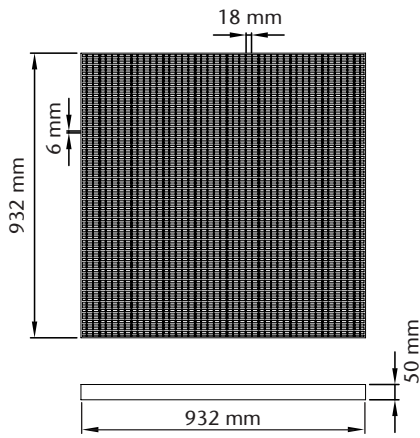

Galvanised Heelguard 2 - Part grate

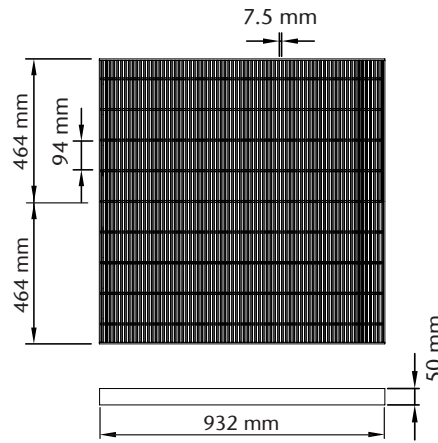

Galvanised Transverse grate

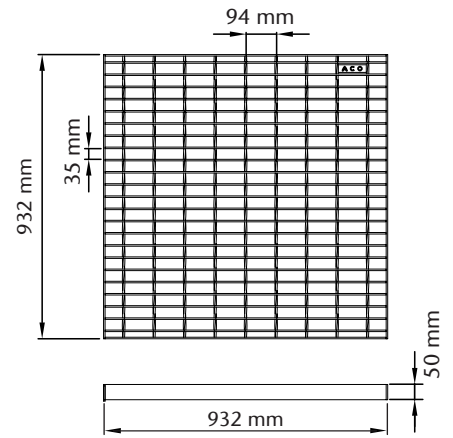

Drainage pit

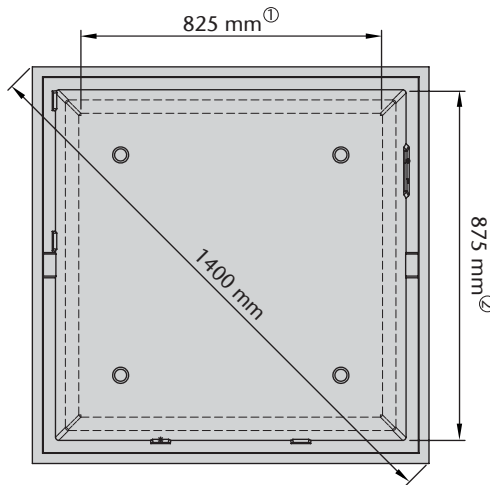

Key

- ① Clear working dimension at pit base.
- ② Clear working dimension at pit opening.
- ③ Pit invert depth.

Recesses beneath rebate on opposite corners to fit ACO's lifting device

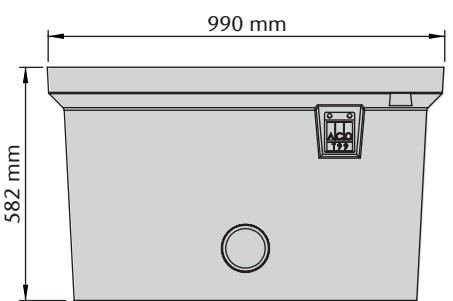
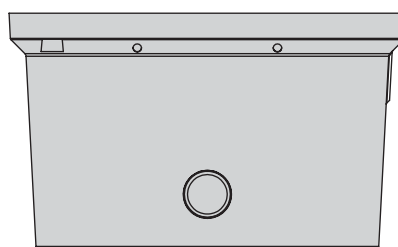
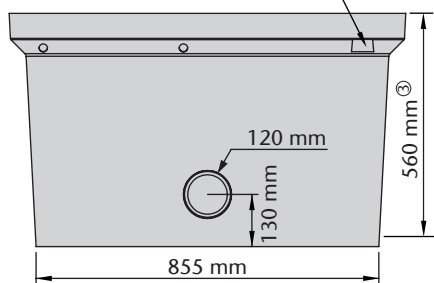

Optional riser

- each riser adds up to 300mm height

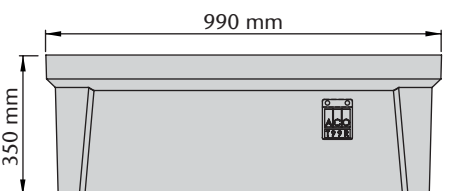
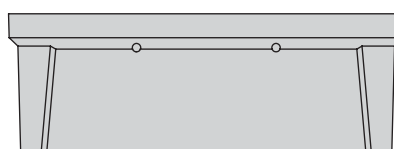
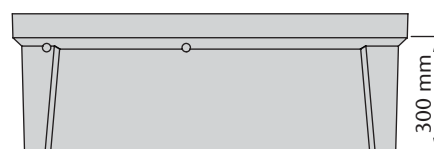
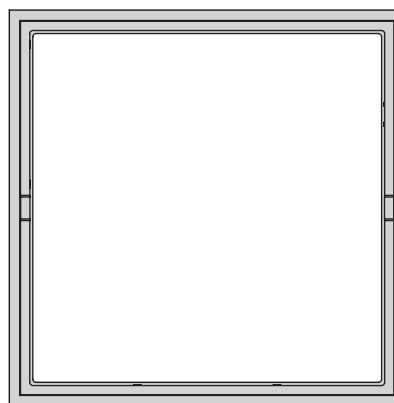

ACO Specification Information

ACO DRAIN®

Type 99 Polycrete® Pit – polymer concrete pit and grate

ACO Specification Information

Pit/riser and grates				
Descriptions	Part No.	Slot Size (mm)	Intake Area (mm ²)	Weight (kg)
Type 99 Polymer concrete pit	76999	-	-	147
Type 99 Polymer concrete riser	77089	-	-	67
Type 99 Stainless 5 Star Heelsafe ® Anti-Slip grate (330kg nominal wheel load)	141813	18 x 6	400,950	34.6
Type 99 Stainless 5 Star Heelsafe ® Anti-Slip grate - locking (330kg nominal wheel load)	142078	18 x 6	400,950	34.6
Type 99 Galvanised Heelguard 2-part grate (2,670kg nominal wheel load)	90083	94 x 7.5	467,500	112
Type 99 Galvanised Heelguard 2-part grate - locking (2,670kg nominal wheel load)	78684	94 x 7.5	467,500	112
Type 99 Galvanised Transverse grate (2,670kg nominal wheel load)	78755	94 x 35	700,800	52.5
Type 99 Galvanised Transverse grate - locking (2,670kg nominal wheel load)	78727	94 x 35	700,800	52.5
Type 99 Galvanised Transverse grate (5,000kg nominal wheel load)	77683	94 x 25	683,280	66.7
Type 99 Galvanised Transverse grate - locking (5,000kg nominal wheel load)	77660	94 x 25	683,280	66.7

Notes:

1. Locking grate includes bar and brackets.
2. Stainless steel grade 304.

Specifications

The grated pit shall be ACO Drain® - Type 99 Polycrete® Pit – polymer concrete pit and grate as manufactured by ACO.

Type 99 pit and risers* shall be manufactured from polyester resin polymer concrete and installed in accordance with the manufacturer's installation instructions.

Type 99 pits have a clear opening of 875mm x 875mm with an invert depth of 560mm. The overall dimensions of the Type 99 pit is 990mm x 990mm x 582mm deep. Type 99 risers add 300mm to the overall depth of the pit.*

Grate for the Type 99 pit shall be standard non-locking / locking* and grate type:

- Stainless 5 Star **Heelsafe**® Anti-Slip grate (330kg nominal wheel load).*
- Galvanised Heelguard 2-part grate (2,670kg nominal wheel load).*
- Galvanised Transverse grate (2,670kg nominal wheel load).*
- Galvanised Transverse grate (5,000kg nominal wheel load).*

* delete as applicable

ACO Pty Ltd

Australia

Ph: 1300 765 226

www.acoaus.com.au

sales@acoaus.com.au

©2019 ACO Pty Ltd. All reasonable care has been taken in compiling the information in this document. All recommendations and suggestions on the use of ACO products are made without guarantee since the conditions of use are beyond the control of the company. It is the customer's responsibility to ensure that each product is fit for its intended purpose and that the actual conditions are suitable. ACO Pty Ltd. pursues a policy of continuous product development and reserves the right to amend specifications without notice.

